



## Indoor Riding Arena Lighting Packages and Photometric Studies

Choosing the right lighting for your riding arena is essential for creating a safe, functional, and enjoyable space. Whether you're practicing dressage, training horses, jumping, roping, or barrel racing, well-designed LED lighting ensures clear visibility, enhances safety, and elevates the overall experience. By investing in high-quality LED fixtures and professional lighting design, you'll create an arena that's optimized for performance, comfort, and success, no matter the activity.



### Arena Lighting Requirements

#### Average Footcandles:

Recreational: 20 to 30 Average Footcandles

Equitation & Jumping: 30 to 40 Average

Footcandles Dressage: Minimum of 50

**Uniform Lighting:** Max/Min ratio of less than 3.0

**Glare Control:** Low-glare <28UGR diffuser optics

**Mounting Height:** Minimum 15 ft, 16+ ft preferred

#### Fixture Durability:

IP65: Wet location protection from dirt and bugs

6kV: Surge protection is standard

IK08: Industrial rating, protected against a 5 joule impact

Choice of Color Temp: 3000K, 4000K, or 5000K

CRI: 80+ for superior color rendering

### Proper Planning

Proper planning is a requirement to achieve your arena's lighting requirements. Access Fixtures lighting specialists and lighting engineers can provide you with a pre-engineered package or a photometric study for your arena and the activities that will take place there. Ensure your project meets safety and performance standards. Contact a Lighting Specialist today.

[Sales@AccessFixtures.com](mailto:Sales@AccessFixtures.com)

[www.AccessFixtures.com](http://www.AccessFixtures.com)

800-468-9925

# HIIO 100 / 120 / 150

HIIO Selectable Wattage, Selectable Kelvin, Rugged LED High Bay Lights Are Built For Indoor Riding Arenas



**Field Configurable:**

HIIO delivers the exact Kelvin and the amount of light that you want with the flick of an intelligent controller switch.

**Premium Optics:**

HIIOs are equipped with a diffuser lens that delivers glare reduction, ensuring visual comfort for riders and horses, reducing eye strain during all activities. An optional refractor lens is available.

**Durable:**

With a die-cast aluminum housing, IP65 wet location rating, 6KV surge protection, IK08 impact resistance, and a shatterproof polycarbonate lens, HIIO is designed and manufactured for indoor riding arenas.

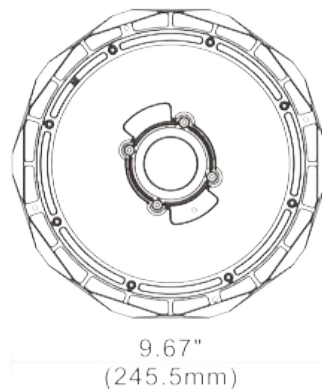
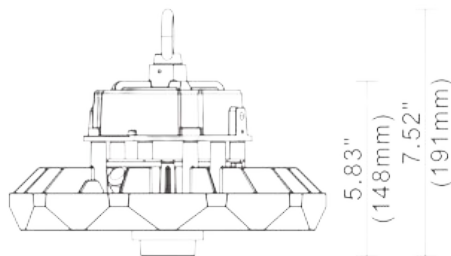

# HIIO 100 / 120 / 150

Optional Plug-and-Play  
Pre-Programmed  
Occupancy Sensor



■ **Occupancy Sensor:**

Designed to provide multi-mode occupancy sensing-based continuous dimming control, ease of use, and the most straightforward installation.

■ **Acrylic Refractor:**

The optional acrylic refractor enhances the glare reduction of the standard <math><28\text{UGR}</math> diffuser lens, providing optimal glare elimination and even light distribution in your riding arena.

Optional Acrylic Refractor  
8.5" Tall - 16.22" Diameter



800-468-9925

[Sales@AccessFixtures.com](mailto:Sales@AccessFixtures.com)

[www.AccessFixtures.com](http://www.AccessFixtures.com)

Line Voltage SmartDIM Occupancy Sensor

**INSTALLATION INSTRUCTIONS**



**OVERVIEW**

The LOD-509 series member of the TRANS family is a line voltage occupancy sensor featuring **SmartDIM** control to the lighting with 0-10V dimmable ballast or driver. **SmartDIM** is a state-of-the-art continuous dimming control technology developed by IR-TEC, which is capable of maintaining the overall ambient light level with the preset range through a smooth continuous dimming control to the connected lighting. The LOD-509 is designed to provide multi-mode occupancy sensing based continuous dimming control, ease of use, and the simplest installation.

This sensor will turn on the connected lighting to the preset SmartDIM level when it detects the presence of an occupant or vehicle, and switch off or to 1/2 of SmartDIM level (as per mode selected) after the area is vacant for a period of time. The LOD-509 offers 8 selectable control modes via a rotary DIP switch setting. Additionally, 7 different delay times can be easily and accurately set via Accu-Set digital potentiometer. The SmartDIM level can be manually adjusted to provide consistent lighting as required. An exclusive Hybrid Switching technology makes this sensor ideal to control lighting with exceptionally high inrush current (HIC) while switching on, such as multiple LED or CFL lights connected in parallel.

Like all sensors in the TRANS family, the LOD-509 series is available with various mounting options and interchangeable lenses. This provides a second-to-none design and complete installation flexibility. The sensor is designed to operate in the coldest of environments, down to -40°C/°F.

**INSTALLATION NOTES**

1. The sensor is more sensitive to the movements “crossing” the detection zones than “toward” or “away” the sensor unit. To obtain better sensitivity, avoid placing the sensor in line with occupant path, if possible.
2. The closer the movement is to the sensor, the more sensitive the sensor is. The higher the sensor is installed, the larger movement is required to be detected.
3. Ensure to place the sensor at least at 1.5m (5 ft.) away from air supply ducts as rapid air flow may cause false activations.
4. The sensor cannot “see” the movements behind obstacles, such as furniture, shelf, glass or partitions. As a general rule, each occupant should be able to clearly view the sensor unit.
5. For open office areas with partition which could block the sensor view to occupant movements, it is best to place the sensors over the intersection of multiple workstations. For large areas of open office or space, place multiple sensors so that there is overlap coverage with each adjacent sensor.

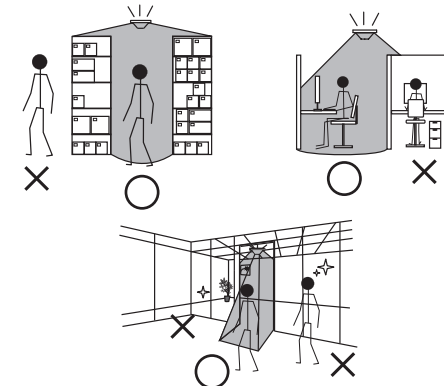

**CAUTION**

- Risk of Electric Shock - Disconnect power supply before servicing.
- Do NOT touch the square window of infrared sensor under the lens assembly.

Open Type Photoelectric Switches.

**PRUDENCE**

- Risque de choc électrique - Débranchez l'alimentation avant l'entretien.
- Ne PAS toucher la fenêtre carrée de capteur infrarouge sous l'ensemble de l'objectif.

Ouvrir Type commutateurs optoélectroniques

## WIRING DIAGRAM

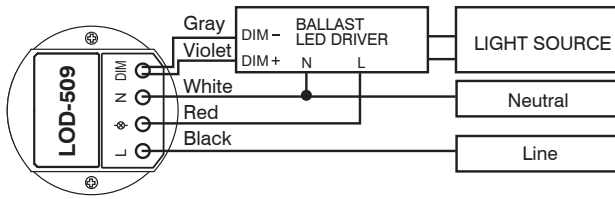

**NOTE:** The driver/ballast **MUST** be 0-10V dimmable to achieve dimming control.

## SENSOR SETTINGS

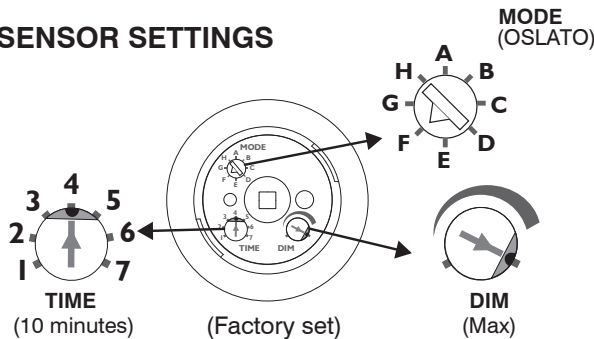

POS.	1	2	3	4	5	6	7
TIME	T	3'	5'	10'	15'	20'	30'

Factory Set

### TIME setting

The sensor provides 7 different times via pointing the TIME potentiometer to different positions (as above table). It is the time period that sensor will activate SmartDIM control to the connected light, starts from detecting the presence of an occupant and ends if no movement is detected before the time elapsed.

### SmartDIM setting

The SmartDIM level of each sensor is factory set at maximum position. If necessary, the SmartDIM level can be decreased by adjusting the potentiometer (DIM) counterclockwise. To achieve proper lighting level, avoid setting the SmartDIM when the space is having abundant daylight.

**NOTE:** If the ambient light level exceeds 2X of SmartDIM level for more than 20 minutes, the sensor may switch off the light even under occupancy.

## TESTING

To verify the sensor control function normal, please proceed with the instructions as below to conduct test;

1. Remove the lens. Set the arrow of TIME potentiometer pointing at position "1" (TEST) and MODE switch at the desired control mode.
2. Walk within the expected range\* at normal speed. The sensor will switch ON (ALS and SmartDIM disabled) the light for 10 seconds whenever sensor detects the movement, and then switch OFF or dim to 1/2 output for 10 seconds as per the selected mode. The LED of sensor will also blink to indicate every motion detected.
3. After testing complete, ensure to set the TIME potentiometer to the position of desired time. **NOTE:** The sensor will automatically control the light as per the selected mode with factory set time delay (10 minutes) if the TIME potentiometer has NOT been set to other position.

\* The coverage may vary with the lens type and mounting height applied. Refer to the attached LENS DATASHEET for more details.

## SPECIFICATIONS

Power supply	120/230/277VAC, 50/60Hz
Maximum Load @ 40°C~55°C (-40°F~131°F)	Incandescent/Halogen - 800/1200W@120/277V
	Fluorescent Ballast/CFL - 800/1200W@120/277V
	Ballast Electronic (LED) - 540/1200VA@120/277V
Maximum Load @ 55°C~70°C (131°F~158°F)	Incandescent/Halogen - 500/750W@120/277V
	Fluorescent Ballast/CFL - 500/750W@120/277V
	Ballast Electronic (LED) - 500/750VA@120/277V
Infrared sensor	Omni-directional quad element pyroelectric
Photo sensor	Digital ambient light sensor
HIC protection	Max. 80A for 16.7msec.
Dim control	0-10V, max 25mA sinking current
Detectable speed	0.15 ~ 3 m/sec. (0.5~10 ft./sec.)
Mounting height	Subject to the lens applied
Detection range	As per lens applied and mounting height
Delay time setting	T/3/5/10/15/20/30 min., T: 10 sec.
Time-off delay	10 min., OSxATO modes only
Op. humidity	Max. 95% RH
Op. temperature	-40°C~70°C (-40°F~158°F)
Dimensions	Ø60 x H37mm (Ø2.36" x H1.45")

## MODE (Control mode selection)

The LOD-509 series features 8 different control modes for selection via rotary DIP switch. Please refer to the following table for selecting the control mode.

Mode	Sensor Control Description
<b>A</b> (ON/OFF)	1. Ambient light sensor is disabled. 2. Turn the light to full-ON as per TIME set under occupancy. 3. Turn off the light after the delay time elapsed.
<b>B</b> (OSO)	1. Ambient light sensor is disabled. 2. SmartDIM controls whenever sensor detects occupancy. 3. Dim to 1/2 of SmartDIM level after delay time elapsed.
<b>C</b> (OSLA)	1. ALS inhibits lighting while ambient light > 50 lux. 2. Dim the light to 1/2 of SmartDIM if ambient light < 20 lux. 3. SmartDIM control as per TIME set under occupancy.
<b>D</b> (OSMA)	1. ALS inhibits lighting while ambient light > 80 lux. 2. Dim the light to 1/2 of SmartDIM if ambient light < 50 lux 3. SmartDIM control as per TIME set under occupancy.
<b>E</b> (OSHA)	1. ALS inhibits lighting while ambient light > 130 lux. 2. Dim the light to 1/2 of SmartDIM if ambient light < 80 lux 3. SmartDIM control as per TIME set under occupancy.
<b>F</b> (OSLATO)	1. ALS inhibits lighting while ambient light > 50 lux. 2. SmartDIM control as per TIME set under occupancy if ambient light < 20 lux. Dim the light to 1/2 of SmartDIM level for 10 min. as Time Off. 3. Turn to SmartDIM control as per TIME set if sensor detects occupancy during Time Off. Turn off the light if no occupancy detected during TO.
<b>G</b> (OSMATO)	1. ALS inhibits lighting while ambient light > 80 lux. 2. SmartDIM control as per TIME set under occupancy if ambient light < 50 lux. Dim the light to 1/2 of SmartDIM level for 10 min. as Time Off. 3. Turn to SmartDIM control as per TIME set if sensor detects occupancy during Time Off. Turn off the light if no occupancy detected during TO.
<b>H</b> (OSHATO)	1. ALS inhibits lighting while ambient light > 130 lux. 2. SmartDIM control as per TIME set under occupancy if ambient light < 80 lux. Dim the light to 1/2 of SmartDIM level for 10 min. as Time Off. 3. Turn to SmartDIM control as per TIME set if sensor detects occupancy during Time Off. Turn off the light if no occupancy detected during TO.

## Frequently Asked Indoor Riding Arena Lighting Questions:

**What type of lighting is best for an indoor riding arena?** LED lighting is by far the best option. It outperforms traditional metal halide and fluorescent systems in energy efficiency, color rendering, startup time, and maintenance. LEDs turn on instantly, offer high CRI (Color Rendering Index) for better depth perception and visibility, and are more environmentally friendly. Equally important, LEDs don't flicker, which can affect both horse comfort and rider focus.

**How bright should the lighting be in an indoor arena?** Brightness depends on arena use. For general recreational riding, 20 to 30 footcandles (fc) is sufficient. For equitation or jumping, use 30 to 40 average fc. Dressage, or events involving speed or precision, require 50 or more fc. Professional or competition-grade arenas might need 75 to 100 fc. Uniformity, how evenly the light is distributed, is just as important as brightness. This is measured using a Max/Min ratio, which is the highest fc in a small area divided by the lowest fc in a similar-sized area. The max/min ratio should be below 3.0.

**How many fixtures do I need?** This depends on the size of your arena, the height of your ceiling, the lumen output of each fixture, and the desired footcandle level. For example, a 100' x 200' arena typically requires 10–20 high-output LED fixtures, each with a lumens output of around 20,000 to 25,000, so it is not too bright when riding by the fixture on horseback. The only reliable way to determine the correct number and placement is to conduct a photometric lighting analysis.

**What color temperature is best for horses and riders?** A color temperature of 4000K to 5000K is ideal. This "neutral white" to "daylight white" range mimics natural daylight, which enhances contrast and detail without appearing too harsh. Lower temperatures, like 3000K, may feel too warm, while anything over 5000K may create an unnaturally stark or cold feeling.

**Are LED lights safe for horses?** Yes. Quality LED fixtures are safe and even beneficial. They produce minimal heat, reducing the risk of burns or overheating. They emit no relevant UV or IR radiation, which can irritate horses' eyes. High-quality drivers also eliminate flicker, which is vital because horses can detect flicker at higher frequencies than humans. LEDs also avoid loud buzzing, unlike aging metal halide or fluorescent systems, which can spook sensitive animals.

**How high should the lights be mounted?** Typical mounting heights range from 16 to 24 feet, depending on the arena ceiling height or trusses, and the beam angle of the fixtures. Higher mounting heights enable wider light distribution and help prevent glare and shadows but may necessitate more powerful fixtures. Uniform spacing along the long sides of the arena helps create even light across the riding surface.

**Should I use direct or indirect lighting?** Direct lighting, fixtures aiming straight down, is more common, practical, and cost-effective. Indirect lighting, fixtures that bounce light off the ceiling, do not work in riding arenas. The ceilings are not white, which reduces or eliminates reflective light. Additionally, dirt will accumulate and birds will nest on the light-emitting surfaces, thereby reducing or eliminating the emitted light. Reflective lighting works when cost is not a concern.

**What about lighting controls, and are they worth it?** Dimming capabilities, motion sensors, and programmable timers can reduce energy costs. For multi-use arenas, dimming is particularly useful for adjusting lighting intensity to accommodate different activities, such as lunging vs. jumping. Occupancy sensors can be annoying, as fixtures may turn on and off depending on settings and sensitivity, while working or riding in the arena.

**How do I avoid shadows that scare horses?** Use fixtures with wide beam angles and ensure even spacing and overlap of light distribution. Position lights to prevent hot spots directly under fixtures and dark zones between them. A photometric layout helps eliminate unintended shadows, which can disorient or frighten horses, especially when approaching obstacles such as jumps.

**Do LED lights work in cold climates?** Absolutely. LEDs perform better in freezing temperatures, unlike fluorescent lights, which may dim or fail to start. Many LED fixtures are rated for temperatures as low as -40°F, making them ideal for use in unheated arenas or during winter conditions.

**Can LED lights be damaged by dust or moisture in the arena?** Yes—if the wrong fixtures are used. Choose lights with a minimum of IP65 rating, which means they're protected against dust ingress and low-pressure water jets. This protects against moisture from humidity and water buckets, as well as dust, hay particles, and ammonia from manure, which can corrode unsealed fixtures over time.

**How long do LED fixtures last in an arena?** High-quality LEDs typically last over 50,000 hours, depending on usage and the quality of the driver. For a facility running lights 6 hours per day, 5 days a week, that's up to 25+ years. LEDs require almost no maintenance—no bulb or ballast replacements—which is a significant advantage in high-ceiling spaces.

**Is glare a problem with LED arena lighting?** It can be, but modern LED fixtures with diffused lenses and precise optics reduce this risk. Optional refractors can reduce glare to even lower levels. Correct mounting height and limiting the quantity of lumens emitted further eliminate direct glare into the eyes of horses or riders. Glare reduction is significant in dressage arenas and when filming or photographing events.

**What are the best types of fixtures?** Look for commercial-grade, high-output fixtures designed for industrial, sports, or agricultural applications. Prioritize fixtures with IK ratings for impact resistance, shatter-proof diffused optics, and IP65 or higher ratings for environmental durability.

**Will LED lighting increase my electric bill?** Unlikely. LEDs use 50–75% less electricity than metal halide or halogen alternatives. Despite higher initial costs, the energy savings yield a payback period of 1 to 3 years. Some arenas report annual savings in the thousands after switching.

**Can I install the lighting myself, or do I need a professional?** It's highly recommended to hire a licensed electrician, and it may be required by local or state ordinance. A licensed electrician ensures code compliance, proper grounding, and optimal wiring, which is essential in dusty or damp equestrian environments.

**How do I start planning my lighting system?** Request a photometric analysis tailored to your arena's dimensions, ceiling height, and intended usage. From there, a lighting specialist can recommend fixtures, layout, and control systems. This ensures your investment meets performance, comfort, and safety needs.



800.468.99256

[www.AccessFixtures.com](http://www.AccessFixtures.com)

[Sales@AccessFixtures.com](mailto:Sales@AccessFixtures.com)

# 90' x 60' Indoor Riding Arena - 15 HIIO High Bays at 16'MH - 50 Footcandles



## LUMINAIRE LIST

Manufacturer	Article name	Item #	Lumens	Light Loss Factor	Connected Load	Quantity	Mounting Height
Access Fixtures	HIIO 150	AF55XLED4630V15445WT (Set at 150W and 4000K)	20320	0.90	154.8w	15	16'-0"

Name	Parameter	Min	Max	Average	Mean/Min	Max/Min
Riding Arena	Perpendicular Illumination	45.9c	59.4fc	52.7fc	1.15	1.30



800-468-9925

Sales@AccessFixtures.com

www.AccessFixtures.com

# 90' x 60' Indoor Riding Arena - 10 150w HIIO High Bays at 16'MH - 35 Footcandles



## LUMINAIRE LIST

Manufacturer	Article name	Item #	Lumens	Light Loss Factor	Connected Load	Quantity	Mounting Height
Access Fixtures	HIIO 150	AF55XLED4630V15445WT (Set at 150W and 4000K)	20320	0.90	154.8w	10	16'-0"

Name	Parameter	Min	Max	Average	Mean/Min	Max/Min
Riding Arena	Perpendicular Illumination	24.9fc	50.3fc	37.4fc	1.50	2.02



800-468-9925

[Sales@AccessFixtures.com](mailto:Sales@AccessFixtures.com)

[www.AccessFixtures.com](http://www.AccessFixtures.com)

# 90' x 70' Indoor Riding Arena - 16 HIIO High Bays at 16'MH - 50 Footcandles

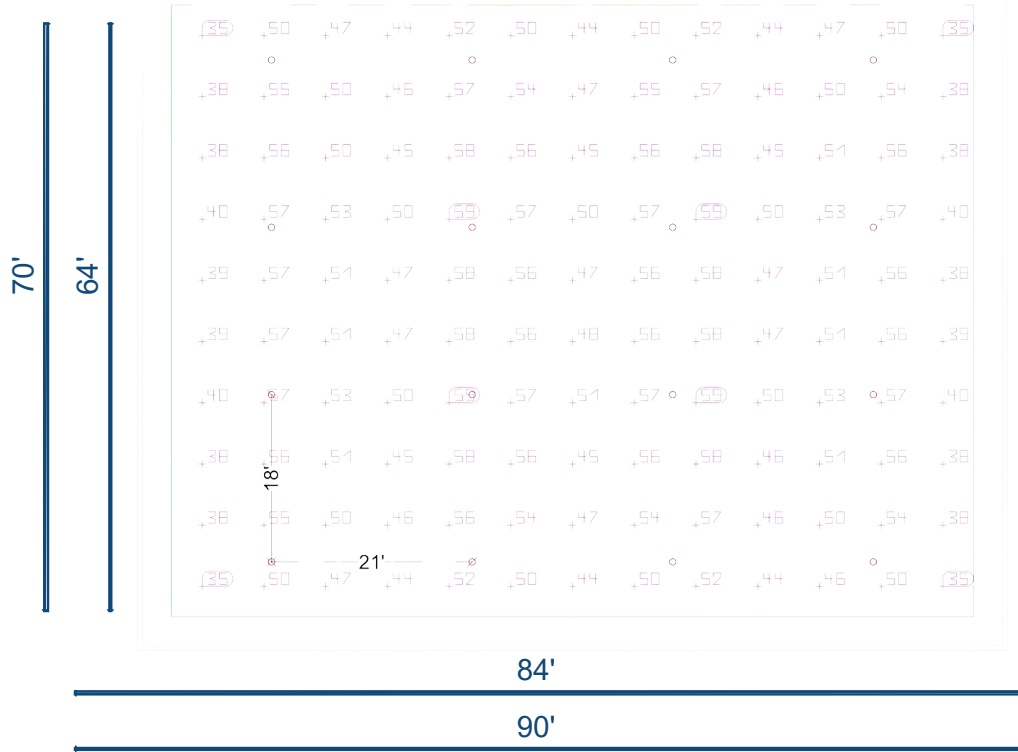

## LUMINAIRE LIST

Manufacturer	Article name	Item #	Lumens	Light Loss Factor	Connected Load	Quantity	Mounting Height
Access Fixtures	HIIO 150	AF55XLED4630V15445WT (Set at 150W and 4000K)	20320	0.90	154.8w	16	16'-0"

Name	Parameter	Min	Max	Average	Mean/Min	Max/Min
Riding Arena	Perpendicular Illumination	35.1fc	59.1fc	49.9fc	1.42	1.69



800-468-9925  
 Sales@AccessFixtures.com  
 www.AccessFixtures.com

# 90' x 70' Indoor Riding Arena - 12 150w HIO High Bays at 16'MH - 35 Footcandles

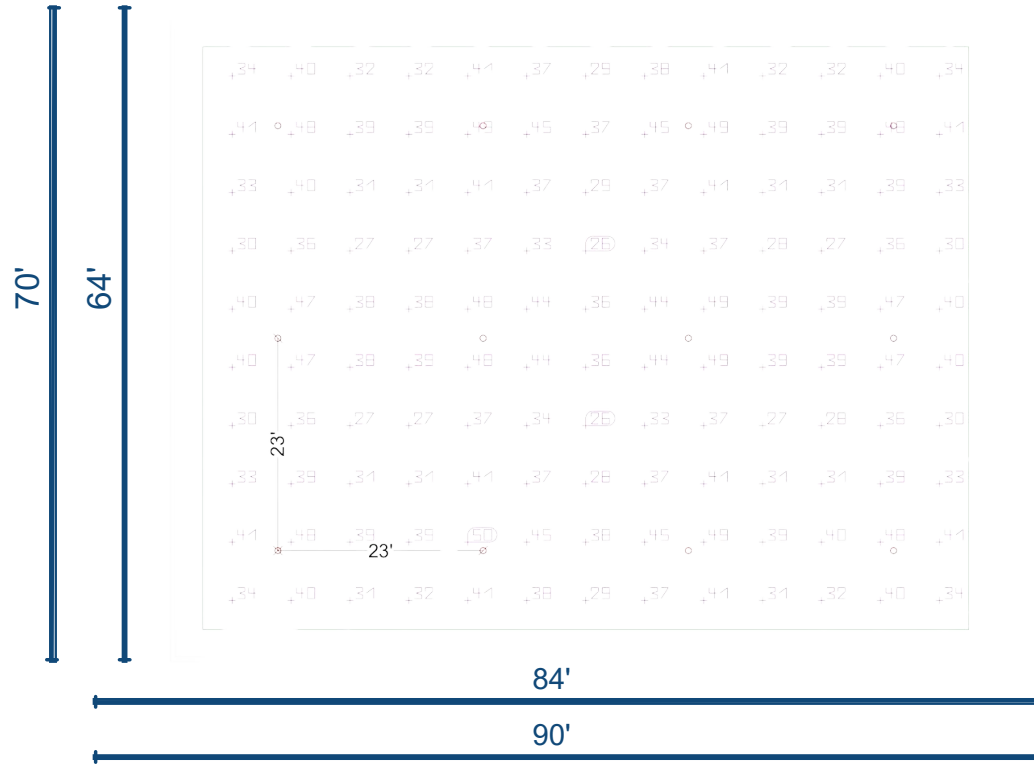

## LUMINAIRE LIST

Manufacturer	Article name	Item #	Lumens	Light Loss Factor	Connected Load	Quantity	Mounting Height
Access Fixtures	HIO 150	AF55XLED4630V15445WT (Set at 150W and 4000K)	20320	0.90	154.8w	12	16'-0"

Name	Parameter	Min	Max	Average	Mean/Min	Max/Min
Riding Arena	Perpendicular Illumination	25.5fc	49.5fc	37.5fc	1.47	1.94



800-468-9925

Sales@AccessFixtures.com

www.AccessFixtures.com

# 90' x 80' Indoor Riding Arena - 20 HIIO High Bays at 16'MH - 50 Footcandles

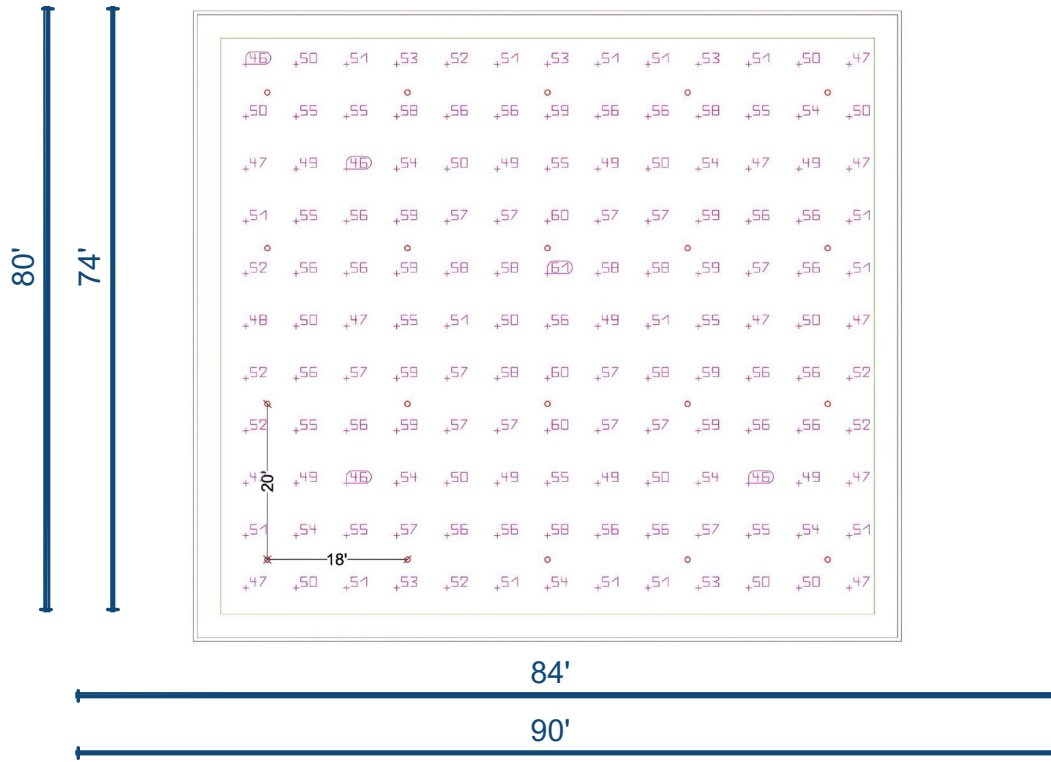

## LUMINAIRE LIST

Manufacturer	Article name	Item #	Lumens	Light Loss Factor	Connected Load	Quantity	Mounting Height
Access Fixtures	HIIO 150	AF55XLED4630V15445WT (Set at 150W and 4000K)	20320	0.90	154.8w	20	16'-0"

Name	Parameter	Min	Max	Average	Mean/Min	Max/Min
Riding Arena	Perpendicular Illumination	46.3fc	60.5fc	53.4fc	1.15	1.31



800-468-9925

Sales@AccessFixtures.com

www.AccessFixtures.com

# 90' x 80' Indoor Riding Arena - 12 150w HIIO High Bays at 16'MH - 35 Footcandles

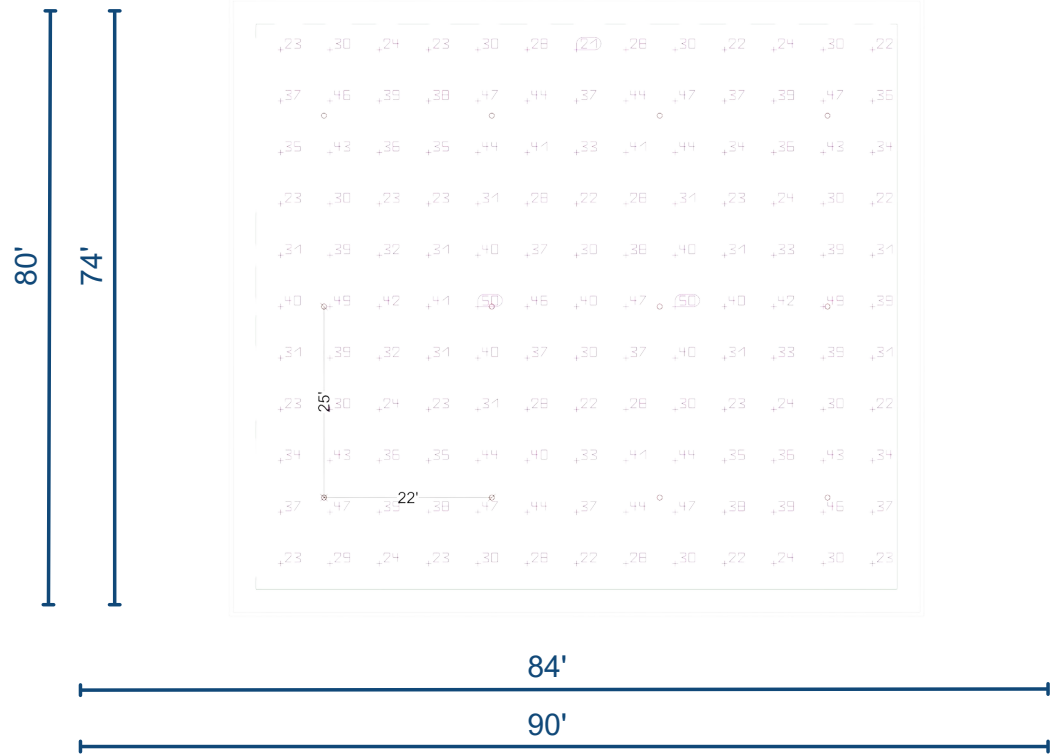

## LUMINAIRE LIST

Manufacturer	Article name	Item #	Lumens	Light Loss Factor	Connected Load	Quantity	Mounting Height
Access Fixtures	HIIO 150	AF55XLED4630V15445WT (Set at 150W and 4000K)	20320	0.90	154.8w	12	16'-0"

Name	Parameter	Min	Max	Average	Mean/Min	Max/Min
Riding Arena	Perpendicular Illumination	21.2fc	50.1fc	34.2fc	1.61	2.36



800-468-9925  
 Sales@AccessFixtures.com  
 www.AccessFixtures.com

# 90' x 100' Indoor Riding Arena - 25 HIIO High Bays at 16'MH - 50 Footcandles

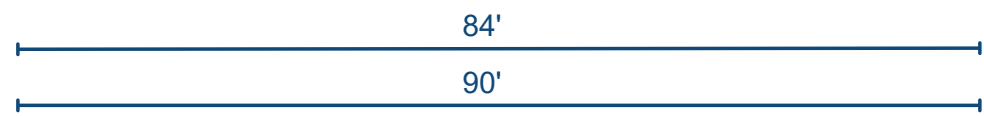
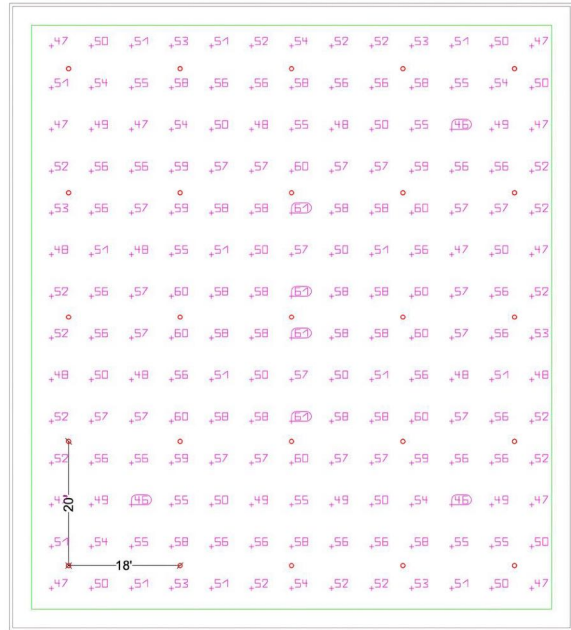

## LUMINAIRE LIST

Manufacturer	Article name	Item #	Lumens	Light Loss Factor	Connected Load	Quantity	Mounting Height
Access Fixtures	HIIO 150	AF55XLED4630V15445WT (Set at 150W and 4000K)	20320	0.90	154.8w	25	16'-0"

Name	Parameter	Min	Max	Average	Mean/Min	Max/Min
Riding Arena	Perpendicular Illumination	46.2fc	60.7fc	53.9fc	1.17	1.31



800-468-9925  
 Sales@AccessFixtures.com  
 www.AccessFixtures.com

# 90' x 100' Indoor Riding Arena - 16 150w H110 High Bays at 16'MH - 35 Footcandles

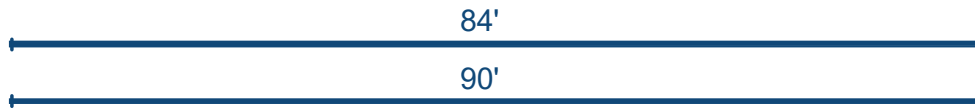
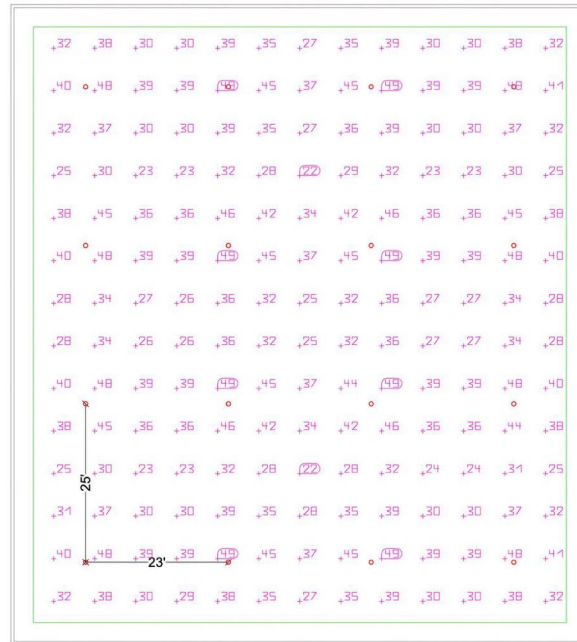

## LUMINAIRE LIST

Manufacturer	Article name	Item #	Lumens	Light Loss Factor	Connected Load	Quantity	Mounting Height
Access Fixtures	H110 150	AF55XLED4630V15445WT (Set at 150W and 4000K)	20320	0.90	154.8w	16	16'-0"

Name	Parameter	Min	Max	Average	Mean/Min	Max/Min
Riding Arena	Perpendicular Illumination	22.1fc	49.1fc	35.5fc	1.61	2.22



800-468-9925  
 Sales@AccessFixtures.com  
 www.AccessFixtures.com